

RIVETTATRICE OLEOPNEUMATICA PER RIVETTI IN CARTUCCIA

OLEOPNEUMATIC TOOL FOR SPEED RIVETS

02FSR2460

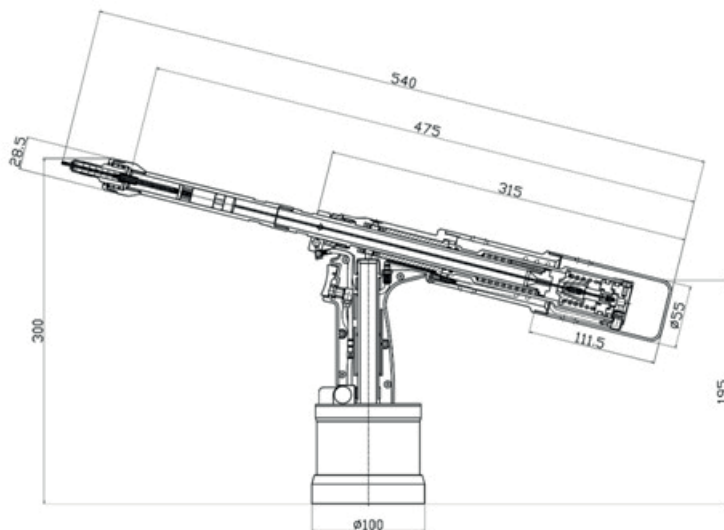

CARATTERISTICHE

Veloce, trigger con una singola azione.
Leggero. Ideale per zone con accessi ridotti.

FEATURES

Fast, single action trigger. Lightweight.
Ideal for areas with restricted access.

CODICE CODE	CARATTERISTICHE TECHNICAL FEATURES			UTILIZZO CAPACITY				
	PRESSIONE DI UTILIZZO PRESSURE REQUIRED	PESO WEIGHT	CORSA STROKE	RIVETTO/RIVET Ø	ALLUMINIO ALUMINIUM	ACCIAIO STEEL	OTTONE BRASS	INOX STAINLESS STEEL
02FSR2460	5 - 7 BAR	1,7 Kg	30 mm	2,4 mm	●		●	
				3,2 mm	●	●	●	●
				4 mm	●	●	●	●
				4,8 mm	●	●	●	●

A seconda del diametro del rivetto e del materiale **si dovranno richiedere** testina, mandrino e molla. *Depending on the diameter and material of the rivet head, mandrel and spring **must be requested.***



Testa / Head



Mandrino / Mandrel





Molla / Spring

TESTE, MANDRINI E MOLLE STANDARD PER RIVETTI IN CARTUCCIA

STANDARD HEADS, MANDRELS AND SPRINGS FOR SPEED RIVETS TOOLS

STANDARD





RIVETTO/ RIVET Ø	Ø FORO/HOLE	TESTA / HEAD		MANDRINI / MANDRELS		MOLLA / SPRING
		PIATTA / FLAT 	CONCAVA / RECESSED 	ALL. / ACC. / OTTONE ALU. / STEEL / BRASS	INOX STAINLESS STEEL	
		CODICE / CODE	CODICE / CODE	CODICE / CODE	CODICE / CODE	CODICE / CODE
2.4	2.36 - 2.44	02H-3001	02H-3002	02M-0183	-	02S-3001
3.2	3.26 - 3.34	02H-4001	02H-4002	02M-0234	02M-S249	02S-4001
	3.39 - 3.47			02M-0246	02M-S262	
	3.51 - 3.59			02M-0259	-	
4.0	3.97 - 4.04	02H-5001	02H-5002	02M-0279	02M-S305	02S-5001
	4.01 - 4.17			02M-0292	02M-S318	
	4.22 - 4.29			02M-0305	-	
4.8	4.87 - 4.95	02H-6001	02H-6002	02M-0358	02M-S389	02S-6001
	5.00 - 5.08			02M-0371	02M-S401	
	5.12 - 5.20			02M-0384	-	
6.0	5.98 - 6.06	02H-7001	02H-7002	02M-0454	-	02S-7001
	6.11 - 6.19			02M-0467	-	
	6.23 - 6.31			02M-0479	-	

La testa concava permette di avere una maggiore deformazione.
Recessed head permits to have a larger deformation.

TESTE, MANDRINI E MOLLE LUNGHI PER RIVETTI IN CARTUCCIA

LONG HEADS, MANDRELS AND SPRINGS
FOR SPEED RIVETS TOOLS

LONG

	TESTA / HEAD				MOLLA / SPRING
	PIATTA FLAT	CONCAVA / RECESSED	CURVA PIATTA CURVED FLAT	CURVA CONCAVA / CURVED RE- CESSED	
					
RIVETTO/ RIVET Ø	CODICE/CODE	CODICE/CODE	CODICE/CODE	CODICE/CODE	CODICE/CODE
2.4					02S-3001L
3.2	02H-4003	02H-4004	02H-4005	02H-4006	02S-4001L
4.0	02H-5003	02H-5004	02H-5005	02H-5006	02S-5001L
4.8	02H-6003	02H-6004	02H-6005	02H-6006	02S-6001L
6.0					02S-7001L

La testa lunga permette di operare meglio in spazi ristretti.

La testa curva è ideale per rivettare vicino ai bordi.

Long head permits to better work in tight spaces.

Curved head is ideal to work close to the edges.

MANDRINI / MANDRELS			
LUNGO / LONG			
		ALL. / ACC. / OTT. ALU / STEEL / BRASS	INOX / STAINLESS STEEL
			
D	Ø foro/hole		
2.4	2.36 - 2.44	02M-0183L	-
3.2	3.26 - 3.34	02M-0234L	02M-S249L
	3.39 - 3.47	02M-0246L	02M-S262L
	3.51 - 3.59	02M-0259L	-
4.0	3.97 - 4.04	02M-0279L	02M-S305L
	4.01 - 4.17	02M-0292L	02M-S318L
	4.22 - 4.29	02M-0305L	-
4.8	4.87 - 4.95	02M-0358L	02M-S389L
	5.00 - 5.08	02M-0371L	02M-S401L
	5.12 - 5.20	02M-0384L	-
6.0	5.98 - 6.06	02M-0454L	-
	6.11 - 6.19	02M-0467L	-
	6.23 - 6.31	02M-0479L	-